

The logo consists of the lowercase letters 'lzf' in a white, sans-serif font. Above the 'z' is a red icon of a crown with three points.

**lzf**

**COLLECTION**  
**2023**



Wood touched by Light

## **COLLECTION 2023**

**TINY** by Ray Power

**VOLIERE** by Bodo Sperlein

**OSCA** by Bodo Sperlein

**CANDELA** by Candela Cort

**ASAP** by Lucas Muñoz

**KACTOS** by Ray Power

**BLACK NOTE CHANDELIER** by Ramón Esteve

**ESTELA** by Mayice

# TINY by Ray Power

## THE HAPPY-GO-LUCKY LIGHT

The Tiny lamp by Ray Power is an utterly unassuming light with a classic silhouette. Made with just a single strip of wood veneer, wrapped twice around the light source, the happy-go-lucky Tiny has an instantly recognisable form.

In Tiny, the warmth of the natural wood veneer is crowned by its handy handle, which allows us to place it wherever it's needed.

### TABLE

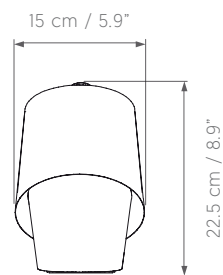

\* Please, consult our sales department for finishes and wood veneer colours



# VOLIERE by Bodo Sperlein

## THE FEATHERY LIGHT

Voliere is a contemporary reinterpretation of a classic 1920s art deco chandelier. With its nod to elegant art deco lighting design, Voliere's intricately layered wood veneer elements are arranged in the manner of feathery plumes. Composed by Bodo Sperlein, Voliere showcases the designer's passion for craft and materiality.

This sculptural lamp's feather-like sections offer a unique perspective when viewed from different angles. Due to the carefully considered structure and materials, the Voliere is lightweight in design.

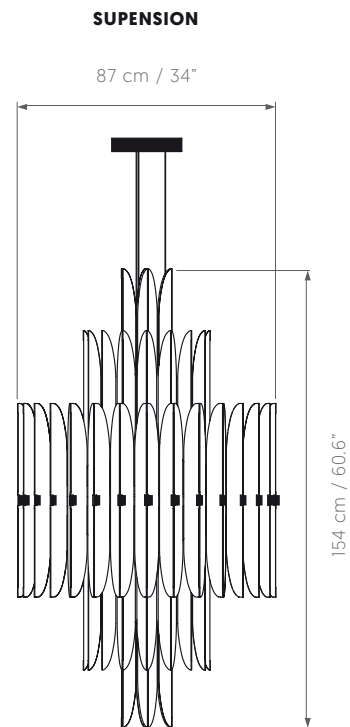

\* Please, consult our sales department for finishes and wood veneer colours



# OSCA by Bodo Sperlein

## THE CUBIST LIGHT

Osca is an architecturally inspired lamp with a cubist aesthetic. In the Osca suspension lamp, simple, interlocking three-dimensional wood veneer arches face both upwards and downwards, giving the lamp a uniquely sculptural form. Designed by Bodo Sperlein, Osca is a minimal collage of shapes.

In its table version, the Osca lamp makes use of a single wood veneer arch—the simple base mirrors the arch shape. The restrained design makes the Osca table lamp ideal for a wide variety of interiors.

LARGE SUSPENSION

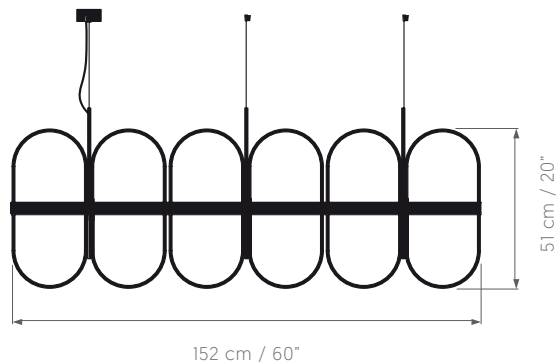

SMALL SUSPENSION

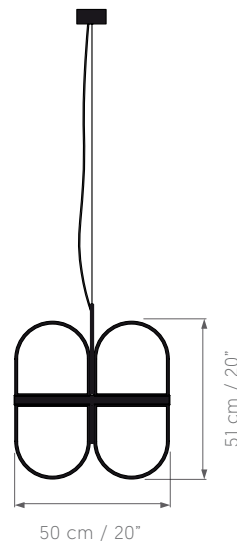

TABLE

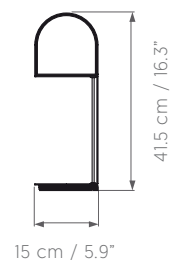

# CANDELA by Candela Cort

## THE VALUE OF THE EXCLUSIVE

The Candela lamp's abstract composition reflects designer Candela Cort's flamboyant career as a milliner. With this symbolic light, Candela alludes to the abstract artwork of the painter Wassily Kandinsky and his assiduous use of geometric form and colour.

The Candela lamp's seemingly chaotic arrangement of geometric elements and strips speak figuratively of life itself: the geometric elements allude to the way in which things come about and the strips of red wicker pith signify maintaining balance.

At Candela, fashion merges with light in singular and unique illuminated works of art, which Candela Cort makes with her own hands, following her instinct and inspiration as if it were a headdress.

Each piece is unique, numbered and signed by the artist.

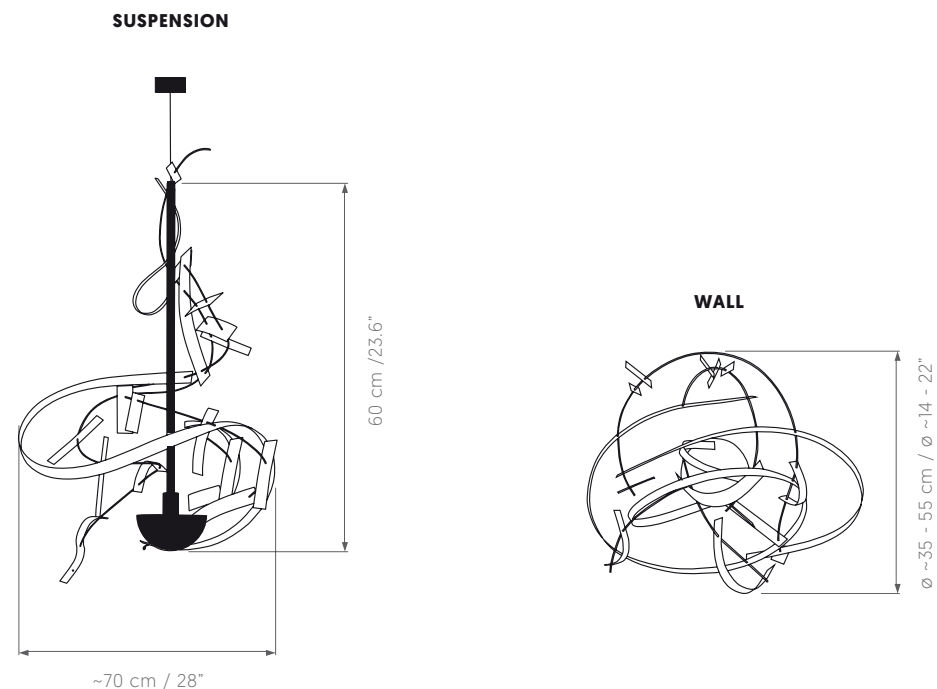

\* Please, consult our sales department for finishes and wood veneer colours



# ASAP by Lucas Muñoz

## THE EXPERIMENTAL LIGHT

The ASAP collection is uniquely experimental. Designed by Lucas Muñoz Muñoz, ASAP is defined by the designer's belief in collaboration, where materials directly interact and work in conjunction. In ASAP, the shape of the natural wood veneer—with its folds, curves, spirals, or circles—is guided using copper rods. The lamp's materials are honestly expressed: the rigid copper rods conduct electricity, the wood veneer diffuses light, and the terracotta base provides stability.

Experimenting with these materials, Lucas Muñoz Muñoz created a light that is noteworthy for its austere simplicity. A minimalist practice of technological sustainability, using primary materials of proximity, recyclable, and low voltage, with bases and supports made with 3D technology, evidencing a sophisticated lamp in the result, with all its components visible.

**CIRCULAR TABLE**

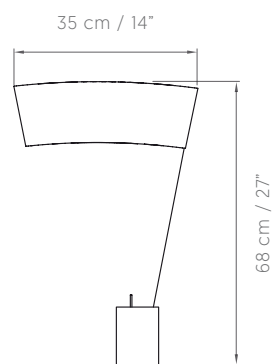

**VELA WALL**

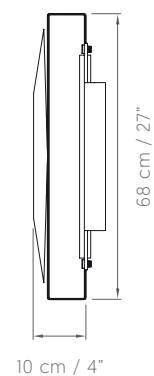

\* Please, consult our sales department for finishes and wood veneer colours





# KACTOS by Ray Power

## THE CACTACEOUS LIGHT

There is nothing prickly about Ray Power's characterful Kactus lamp. With its cactus-like silhouette, the tactile, nature-inspired Kactus is available in both suspension and table versions.

To create the shape, panels of wood veneer are arranged in a vertical concave fashion around the light source and held in place by an acrylic frame. Each piece of veneer beautifully reflects the light from within this pleasing lamp.

### SUSPENSION

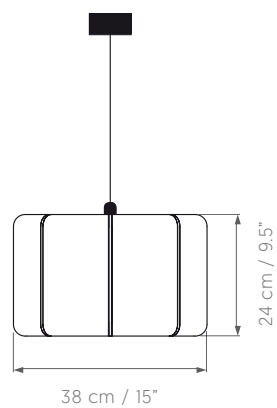

### TABLE

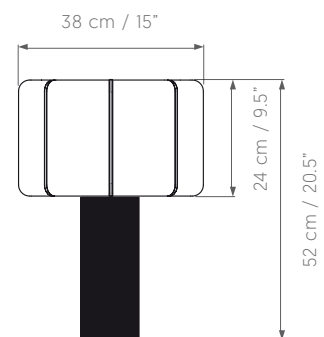

\* Please, consult our sales department for finishes and wood veneer colours



# BLACK NOTE CHANDELIER

by Ramón Esteve

## THE RHYTHMIC LIGHT

In a new composition, the wood veneer “keys” of the Black Note collection, designed by Ramón Esteve, are now configured to imagine a dramatic suspension chandelier.

The different cylinders shades are distributed along its central axis, creating an evocative and protagonist centrepiece, like the roots of a noble tree.

### CHANDELIER SUSPENSION

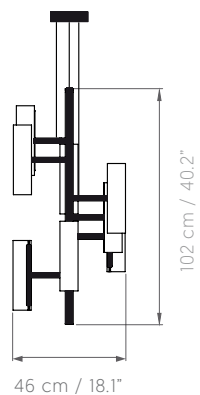

### KEYS SUSPENSION

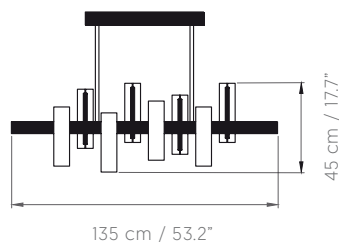

### TRIPLET SUSPENSION

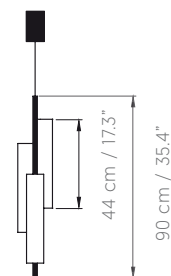

### TRIPLET FLOOR

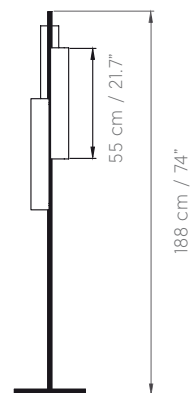

### DUPLET WALL

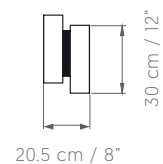

\* Please, consult our sales department for finishes and wood veneer colours



# ESTELA by Mayice

## THE CAPSULE OF LIGHT

Estela is a captivating capsule of light. In Estela, Mayice designed a clean, clear, single piece of borosilicate glass. Hand-blown by the accomplished artisan Eduardo Garuti, the glass envelops the cylindrical wood veneer, offering myriad nuances.. The wood veneer houses a dimmable LED light source, and a straight opening on one side emits light that is softened by the glass.

Offering a seamless connection between both glass and wood, Estela is a radiant lamp with an elegant and sober presence. Estela's natural imperfections, a characteristic of hand-blown glass, add to its warmth and elegance.

The new Estela floor version completes the family, wrapping the characteristic LZF natural wood veneer with a 170 cm high glass cylinder.

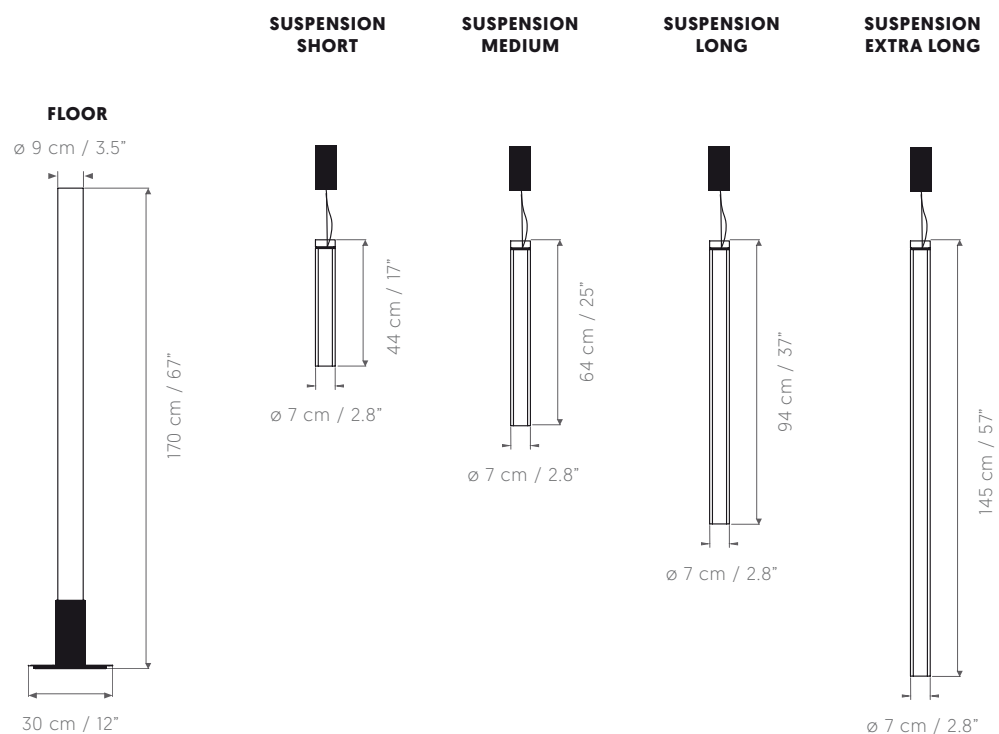

\* Please, consult our sales department for finishes and wood veneer colours



# CREDITS

**MARIVÍ CALVO** Art Director

**JANA TOTHILL** Assistant Art Director

**MANU TORO** Photography

**VASILIS PAPPAS** Lighting

**SYBILLA** Wardrobe

**OLIVIA AGUADE** Make up

**THANK'S TO** Jose, Amanda, Gumba & Cuca

**LZF LAMPS**  
lzf-lamps.com



**Wood touched by Light**

Handmade wood veneer lamps, since 1994